

WS2812 Breakout Hookup Guide a learn.sparkfun.com tutorial

Available online at: <http://sfe.io/t105>

Contents

- [Introduction](#)
- [WS2812 Hardware Overview](#)
- [LilyPad Pixel](#)
- [Addressable LED Strips](#)
- [Addressable Through-Hole LED](#)
- [Hardware Hookup](#)
- [Adding Firmware](#)
- [Resources and Going Further](#)

Introduction

The addressable WS2812 and [WS2812B](#) are unassuming RGB LEDs with an integrated control circuit hidden underneath. We love the simplicity of this little IC/LED combo. It's at the heart of a number of products.



[SMD LED - RGB WS2812B \(Strip of 50\)](#)

COM-16346

\$25.95

1

[Favorited Favorite](#) 13

[Wish List](#)



[SMD LED - RGB WS2812B \(Whole Reel\)](#)

COM-16347

\$499.95

[Favorited Favorite 4](#)

[Wish List](#)

To name a few, the WS2812B is included in the simple [WS2812B Breakout Board](#).

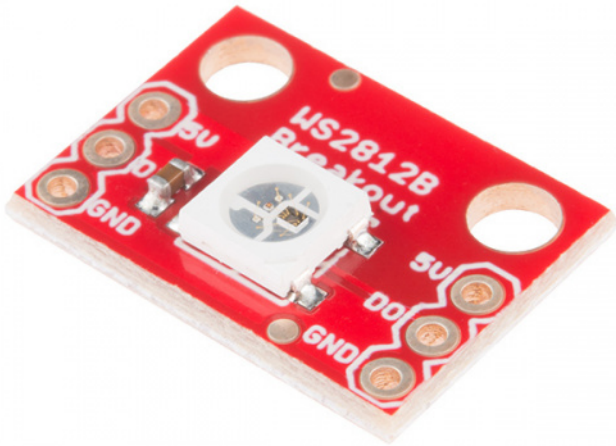

[SparkFun RGB LED Breakout - WS2812B](#)

BOB-13282

\$4.50

2

[Favorited Favorite 22](#)

[Wish List](#)

Sewable LEDs

The [LilyPad Pixel](#) shares the same circuit as the breakout board, but it comes on a circular, purple LilyPad board. These are perfect for sewing onto clothing or other fabric, and embedding into an e-textiles project.



[LilyPad Pixel Board](#)

DEV-13264

Retired

[Favorited Favorite](#) 18

[Wish List](#)

LED Strips

The WS2812B serves as the heart and soul of a variety of LED strips. These strips come in sealed and unsealed [5 meter sealed](#), [1m sealed](#), [5m bare](#), and [1m bare](#).



[LED RGB Strip - Addressable, Bare \(1m\)](#)

COM-12025

7 Retired

[Favorited Favorite](#) 13

[Wish List](#)



[LED RGB Strip - Addressable, Bare \(5m\)](#)

COM-12026

2 Retired

[Favorited Favorite](#) 13

[Wish List](#)



[LED RGB Strip - Addressable, Sealed \(1m\)](#)

COM-12027

8 **Retired**

[Favorited Favorite](#) 12

[Wish List](#)



[LED RGB Strip - Addressable, Sealed \(5m\)](#)

COM-12028

1 **Retired**

[Favorited Favorite](#) 14

[Wish List](#)

Looking for smaller, higher density strips, or ones that emit on the side of the strip? The WS2812B's can also be manufactured in smaller packages such as the ones listed below.



[Skinny LED RGB Strip - Addressable, 1m, 60LEDs \(SK6812\)](#)

COM-14730

Retired

[Favorited Favorite](#) 6

[Wish List](#)



[Skinny Side-Lit LED RGB Strip - Addressable, 1m, 60LEDs \(SK6812\)](#)

COM-14731

2 **Retired**

[Favorited Favorite](#) 2

[Wish List](#)



[Skinny LED RGB Strip - Addressable, 1m, 144LEDs \(SK6812\)](#)

COM-14732

3 **Retired**

[Favorited Favorite](#) 6

[Wish List](#)

Note: While APA102's are not compatible with the WS2812's, the APA104's are compatible with the WS2812B's!



[LED RGB Strip - Addressable, Sealed, 1m \(APA104\)](#)

COM-15205

\$26.95

[Favorited Favorite 4](#)

[Wish List](#)



[LED RGB Strip - Addressable, Bare, 1m \(APA104\)](#)

COM-15206

Retired

[Favorited Favorite 4](#)

[Wish List](#)

Fairy Lights

Fairy lights connect each individual LED with strands of wire. These are more flexible compared to the flexible PCBs that are used in LED strips. These can bend easier and are great for wearable projects if you need to connect a lot of addressable LEDs. Just sew the wire against your fabric to hold down the fairy lights. These are easy to wrap around an object for decor or prop.



[Fairy Lights - Addressable RGB \(5m\)](#)

PRT-16792

\$21.50

5

[Favorited Favorite 6](#)

[Wish List](#)

Matrices, Rings, and Stick

Depending on the project, they can also be populated on PCBs as a matrix, ring, or stick. These can be useful for marquees or adding unique animations to your project!



[NeoPixel Stick - 8 x WS2812 5050 RGB LED](#)

COM-12661

5

[Favorited Favorite 18](#)

[Wish List](#)



[NeoPixel NeoMatrix 8x8 - 64 RGB LED](#)

COM-12662

Retired

[Favorited Favorite](#) 14

[Wish List](#)



[NeoPixel Ring - 16 x WS2812 5050 RGB LED](#)

COM-12664

3 Retired

[Favorited Favorite](#) 26

[Wish List](#)



[NeoPixel Ring - 24 x WS2812 5050 RGB LED](#)

COM-12665

Retired

[Favorited Favorite](#) 19

[Wish List](#)

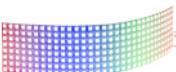

[Flexible LED Matrix - WS2812B \(8x32 Pixel\)](#)

COM-13304

6 Retired

[Favorited Favorite](#) 28

[Wish List](#)



[Pimoroni Unicorn HAT](#)

DEV-14037

1 Retired

[Favorited Favorite](#) 16

[Wish List](#)

Warm White, Cool White, and Amber

Looking for a more natural white instead of mixing RGB? There are also WS2812's that have warm white, cool white, and amber color. Add ambient or task lighting to your projects with the tri-color strips.!



[White Tri-Color LED Strip - Addressable, Sealed \(1m\)](#)

COM-13898

2 Retired

[Favorited Favorite 4](#)

[Wish List](#)

Through-Hole Packages

Lastly, if you require WS2812B LEDs in through-hole form, they are also available as a through-hole package. The size of the bulb can either be 8mm or 5mm. The LEDs can be diffused or clear depending on how they were manufactured: [Diffused 8mm \(5 Pack\)](#), [Diffused 5mm \(5 Pack\)](#), and [Clear 5mm \(5 Pack\)](#).



[LED - RGB Addressable, PTH, 5mm Diffused \(5 Pack\)](#)

COM-12986

\$3.50

8

[Favorited Favorite 23](#)

[Wish List](#)



[LED - RGB Addressable, PTH, 5mm Clear \(5 Pack\)](#)

COM-12999

\$3.50

3

[Favorited Favorite 21](#)

[Wish List](#)



[LED - RGB Addressable, PTH, 8mm Diffused \(5 Pack\)](#)

COM-12877

\$3.50

4

[Favorited Favorite 23](#)

[Wish List](#)

What makes the WS2812B really special is the way its controlled. The IC embedded into the LED communicates via a very **unique one-wire** interface. With the

help of some libraries, they're really very easy to control. Plus they're chain-able -- the output of one LED can be connected to the input of another to create strips of hundreds of LEDs. The more boards you have linked together, the fancier your animations can be!

In this tutorial we're going to get you familiar with the workings of the WS2812 and WS2812B. We'll go over some of the ways you might want to hook up to the breakout board, LilyPad, or strips. And we'll close the tutorial out with some example Arduino code.

Required Materials

WS2812-Based LED Board or Strip

Stating the obvious: you'll need a WS2812-based board or strip. The more the merrier! In the example hookup, we'll be linking together five breakout boards, but the example should be adaptable to the other WS2812-based products. Grab however many you think you'll need for your project, regardless of how many you have, it's not enough.

Microcontroller

Aside from the star of the show, you'll also need a **microcontroller**. Something that can send the series of 1's and 0's used to control the LEDs. Our go-to is the classic [Arduino Uno](#), but any [Arduino board](#) should do.



[Arduino Pro Mini 328 - 5V/16MHz](#)

DEV-11113

\$10.95

140

[Favorited Favorite](#) 174

[Wish List](#)

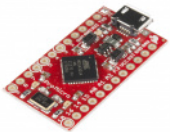

[Pro Micro - 5V/16MHz](#)

DEV-12640

\$19.50

81

[Favorited Favorite](#) 91

[Wish List](#)

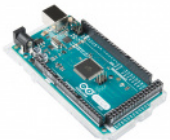

[Arduino Mega 2560 R3](#)

DEV-11061

\$48.40

60

[Favorited Favorite](#) 87

[Wish List](#)



[Arduino Uno - R3 SMD](#)

DEV-11224

\$26.30

26

[Favorited Favorite](#) 34

[Wish List](#)

Limitation on AVR-based Microcontrollers :If you are using an AVR-based microcontroller for large LED installations, there is a limitation with the number of WS2812s LEDs used. This is dependent on the microcontroller's memory and the size of the program. For an ATmega328P-based microcontroller (i.e. RedBoard Programmed with Arduino, Arduino Uno, Arduino Pro Mini, etc.), it can be up to ~300-400 LEDs. Check out Katerborg's note about using WS2812's with different Arduinos:

[Katerborg: Powering Lots of LEDs from Arduino](#)

If you want to get really crazy, [hackaday](#) demonstrates how to power 1000 NeoPixels with the Arduino's limited RAM.

[Hackaday: Driving 1000 Neopixels With 1K Of Arduino RAM](#)

Or you can try to adapt the example code to your favorite microcontroller. Teensy development boards are an excellent choice when using a large number of WS2812 LEDs.



[Teensy LC](#)

DEV-13305

17 **Retired**

[Favorited Favorite](#) 36

[Wish List](#)

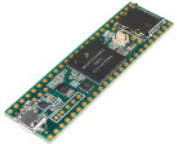

[Teensy 3.5](#)

DEV-14055

8 **Retired**

[Favorited Favorite](#) 21

[Wish List](#)



[Teensy 3.6](#)

DEV-14057

15 **Retired**

[Favorited Favorite](#) 39

[Wish List](#)

Note: Depending on the amount of WS2812 LEDs that are being used with the Teensy, you may need to use the octows2811 adapter board:

[PJRC: OctoWS2811 LED Library](#)

Wires

You'll also need some **way to connect** between the board and an Arduino. You could use a combination of [male headers](#) and breadboard ([solderless](#) or [solderable](#)). Or you could just go with a few pieces of [hookup wire](#) or [3-pin JST-SM pigtail connectors](#).

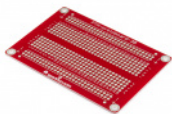

[SparkFun Solder-able Breadboard](#)

PRT-12070
\$5.50
18
[Favorited Favorite](#) 64
[Wish List](#)



[Break Away Headers - Straight](#)

PRT-00116
\$1.75
20
[Favorited Favorite](#) 145
[Wish List](#)



[LED Strip Pigtail Connector \(3-pin\)](#)

CAB-14575
\$1.50
[Favorited Favorite](#) 7
[Wish List](#)



[Breadboard - Translucent Self-Adhesive \(Red\)](#)

PRT-11317
\$5.50
1
[Favorited Favorite](#) 20
[Wish List](#)

Tools

In order to get a good, solid, electrically-sound connection to the breakout boards, you'll need **to solder** to the pins. That means you'll need at least [a basic soldering iron](#), [solder](#), and [general soldering accessories](#). Check out our [how to solder tutorial](#) for help, if this is your first time soldering.



[Solder Lead Free - 100-gram Spool](#)

TOL-09325

\$9.95

8

[Favorited Favorite 40](#)

[Wish List](#)



[Soldering Iron - 30W \(US, 110V\)](#)

TOL-09507

\$10.95

7

[Favorited Favorite 22](#)

[Wish List](#)

Suggested Reading

These boards aren't too hard to use. If you've done anything with Arduino before, you'll be prepared to work with the WS2812. If you're not exactly sure what this "Arduino" thing is, or if you're not familiar with the topics below, consider reading their tutorials:

[How to Solder: Through-Hole Soldering](#)

This tutorial covers everything you need to know about through-hole soldering.

[Favorited Favorite 75](#)

[Binary](#)

Binary is the numeral system of electronics and programming...so it must be important to learn. But, what is binary? How does it translate to other numeral systems like decimal?

[Favorited Favorite 56](#)

[How to Power a Project](#)

A tutorial to help figure out the power requirements of your project.

[Favorited Favorite 70](#)

[How to Use a Breadboard](#)

Welcome to the wonderful world of breadboards. Here we will learn what a breadboard is and how to use one to build your very first circuit.

[Favorited Favorite 82](#)

[What is an Arduino?](#)

What is this 'Arduino' thing anyway? This tutorial dives into what an Arduino is and along with Arduino projects and widgets.

[Favorited Favorite 56](#)

WS2812 Hardware Overview

Note: Make sure to not confuse the WS2812-based IC with the APA102 addressable LEDs. The APA102 LEDs are very similar to WS2812s with a few caveats: APA102s can be controlled with a standard SPI interface, and they have an extremely high PWM frequency. The APA102 requires the [FastLED library](#) to control. The FastLED library does support the WS2812 chipset. Try checking out the [Lumenati Hookup Guide](#) that uses the APA102-based LEDs for more information.

The WS2812-based LED is much more than meets the eye. It may look like a common 5050-sized (5x5mm) LED, but there's actually an [integrated circuit](#) embedded inside there too. If you look really hard, you can see the tiny black chip hidden in there, along with minuscule gold wires connecting the chip to the LED. Below are images of the WS2812 and WS2812B zoomed in.

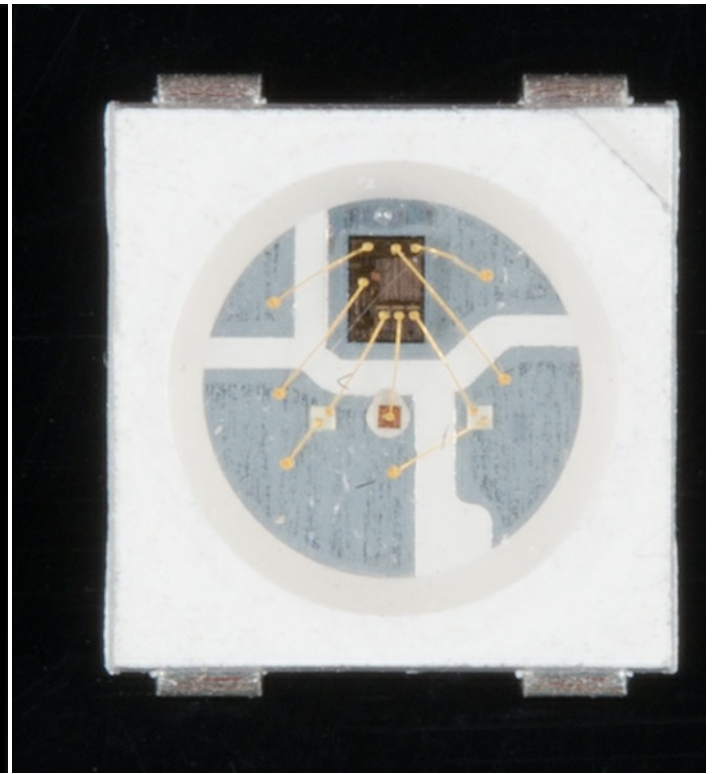
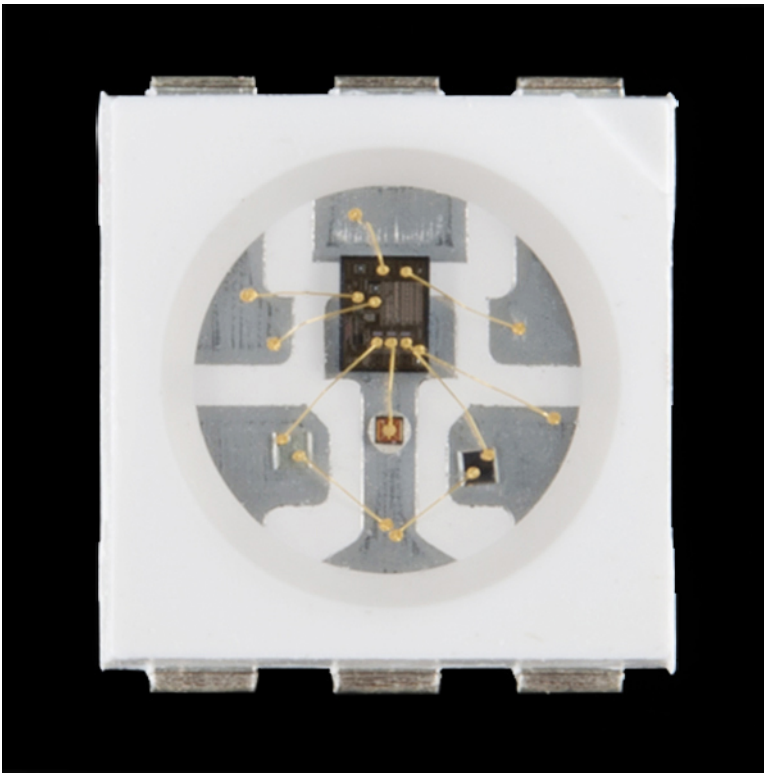

Pretty nifty view at the guts of the WS2812.

Another nifty view for the WS2812B.

The LED itself is like any RGB (Red/Green/Blue) LED. The brightness of each color can be adjusted using [pulse-width modulation](#) to one of 256 different levels. That means there are 16,777,216 (256^3) possible combinations of colors. You can produce any color from white to black (off), or salmon to sienna.

Breakout Board Pinout

The breakout board mounts that multi-talented LED onto a PCB, and breaks out the few pins required to control the LED.

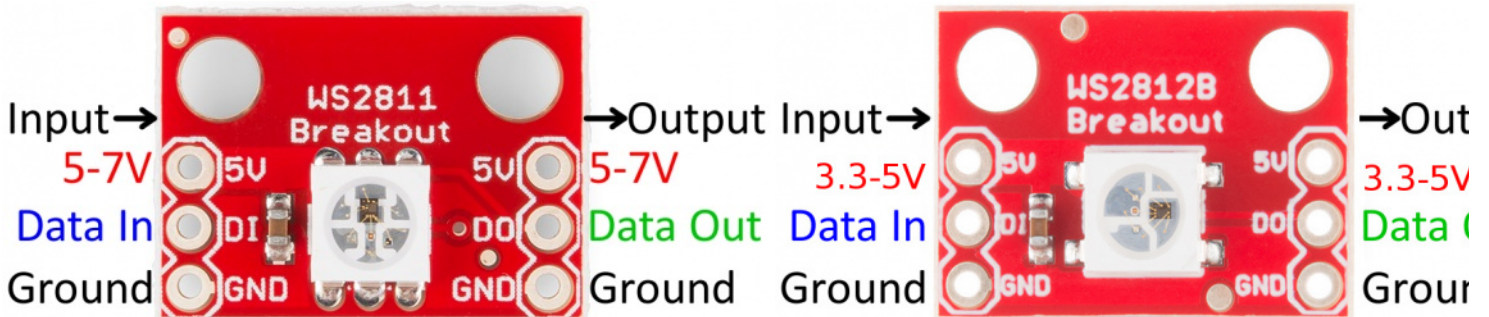

Retired WS2812 breakout board's pinout.

WS2812B breakout board's pinout.

Four unique pins are broken out:

- "5V" - The input voltage will can vary based on the IC version's specifications:
 - **WS2812** -- This should be a **regulated** supply voltage between **5V** and about **7V**. More than that could harm the LED, less than 5V will either reduce brightness, or it just won't turn on.
 - **WS2812B** -- This should be a **regulated** supply voltage between **3.3V** and about **5V**.
- **GND** -- The common, ground, 0V reference supply voltage.
- **DI** -- Data from a microcontroller (or another WS2812/WS2812B pixel) comes into this pin.
- **DO** -- Data is shifted out of this pin, to be connected to the input of another pixel or left floating if it is the last link in the chain.

We recommend matching the input voltage with the [logic level](#) for the data lines (DI and DO). So if you are powering the WS2812B breakout board with 5V, you will be connecting DI and DO with a logic level of 5V.

Data Transmission Interface

Note: This stuff is ugly, and not critical to understand if you just want to use the breakout board. (That's what libraries are for, right?!) It's interesting to talk about, because the interface is so unique.

The communication interface between a microcontroller and the WS2812 is weird. It's one wire, but it's not like a standard, UART [serial interface](#). This interface is very time-specific. Both a logic 0 and a logic 1 require a square pulse, and it's the length of the pulse that defines which it is.

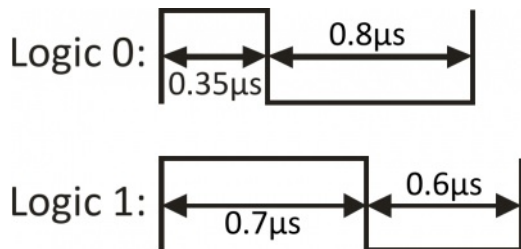

Timing diagram for a single bit of value 0 or 1.

The data is sent in a sequence containing 24 of those bits -- 8 bits for each color -- followed by a low "reset" pulse of at least $50\mu\text{s}$.

G7	G6	G5	G4	G3	G2	G1	G0	R7	R6	R5	R4	R3	R2	R1	R0	B7	B6	B5	B4	B3	B2	B1	B0
----	----	----	----	----	----	----	----	----	----	----	----	----	----	----	----	----	----	----	----	----	----	----	----

A sequence of 24 timed-bits sets the color for each channel. 8-bits per channel. Green first, then red, then blue.

The larger the value of a specific color is, the brighter it will be. If every color is set to 0, the LED will be off. If every color is set to max -- 255 -- the LED will be as bright and white as can be.

This is all to say that the interface is **very time-specific**. To run the LEDs you'll need a real-time processor, like an Arduino; microprocessors like those on the [Raspberry Pi](#) or [pcDuino](#) can't give you a reliably-timed pulse. Even if one bit is less than a microsecond off, that could mean the difference between purple and maroon.

LilyPad Pixel

Want to embed the WS2812 LEDs into your clothing? We have a thing for that! The [LilyPad Pixel Board](#) is the e-textile version of the WS2812 Breakout. The functionality and pinouts are exactly the same, though the pins are in slightly different location to make threaded traces easier.

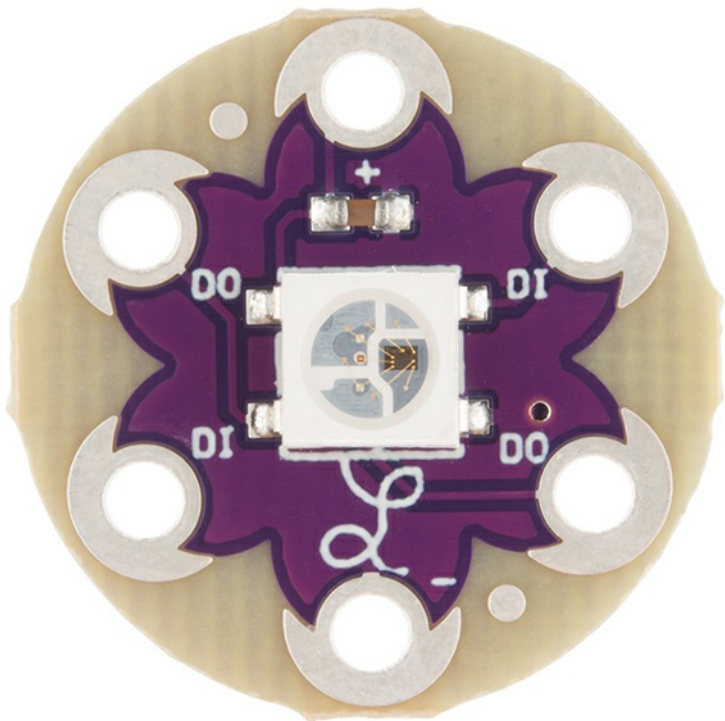

Rather than solder these boards, you can use [conductive thread](#) to connect them to other LilyPad boards. You can control individual LEDs, or chain them together to create a multitude of colors on your clothing. The examples in this tutorial use the WS2812 Breakout, but you can substitute the LilyPad Pixel for any of the breakout boards.

For more information on the LilyPad Pixel Board, check out this other tutorial.

[LilyPad Pixel Board Hookup Guide](#)

[September 16, 2015](#)

Add changing colors to your wearable projects using LilyPad Pixel Boards.

[Favorited Favorite 6](#)

Addressable LED Strips

If you need an abundance of WS2812 LEDs in a slick, pre-assembled form factor these addressable LED strips might be for you.

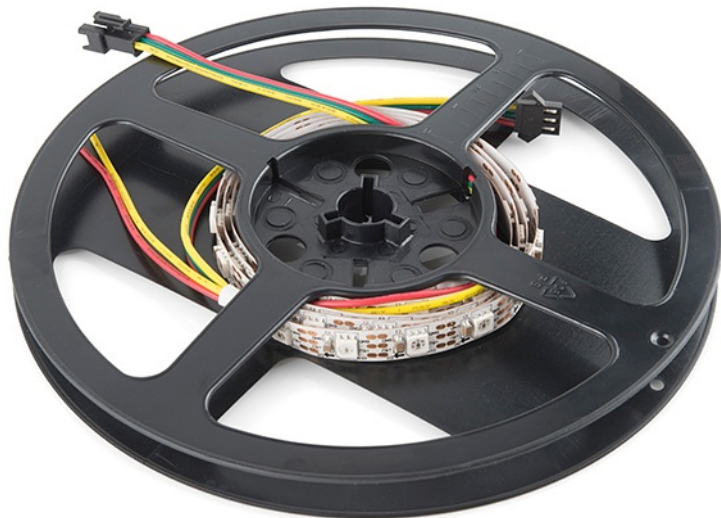

The LED strips come on a reel as shown above.

The WS2812 addressable LED strips come in a few flavors, which vary by size and sealant. You can get them in either 1m or 5m lengths, high density, or side emitting. For each length the strip, they can be either covered by a waterproof sealant or left bare. Below are a [few listed from the catalog](#).

- [5m Sealed](#)
- [1m Sealed](#)
- [5m Bare](#)
- [1m Bare](#)
- [1m Bare, Skinny](#)
- [1m Bare, Skinny, High Density](#)
- [1m Bare, Skinny, Side Lit](#)
- [1m Sealed, White Tri-Color](#)
- [5M Fairy String Lights](#)

Each strip usually contains **60 LEDs per meter**, which are spaced about 1.65cm away from each other. Higher density strips with the smaller IC packages contain **144 LEDs per meter**, which are spaced about 0.69cm from each other. The waterproofed strips are rated [IP65](#) -- dust tight and protected from water jets.

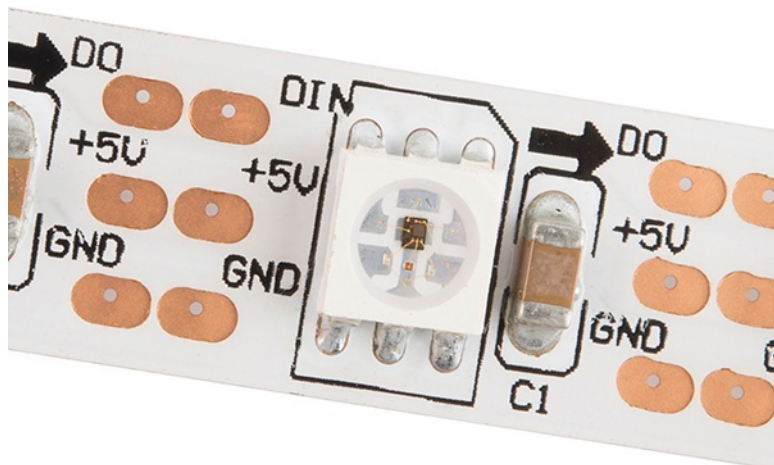

[Connecting to the Strips](#)

Each end of the LED strip is terminated with a set of three colored wires: red, green, and yellow. Two wires are for power, and the third transmits data either into

or out of the strip:

Wire Color	Function	Notes for the WS2812	Notes for the WS2812B and Compatible LEDs	Alternate Wire Color w/ the Compatible APA104	Alternate Wire Color for Addressable Fairy Lights
Red	Vcc	WS2812 power supply. Should be a regulated supply between 5V and 7V .	WS2812B power supply. Should be a regulated supply between 3.3V and 5V .	Red	Red Stripe
Green	Data In/Out	Serial data in/out. Look at arrows and labels on strip to check which it is.	Serial data in/out. Look at arrows and labels on strip to check which it is.	Green	Clear
Yellow	GND	Ground. 0V.	Ground. 0V.	White	Clear

Each of the wire pigtails are terminated by a three-pin JST SM connector, which you can use to connect **string strips together**. Typically, the addressable LEDs use a polarized JST SM connector with the female housing receptacle (with male pins) connected to the DIN side and the male housing receptacle with (female pin sockets) coming connected to the DOUT side.

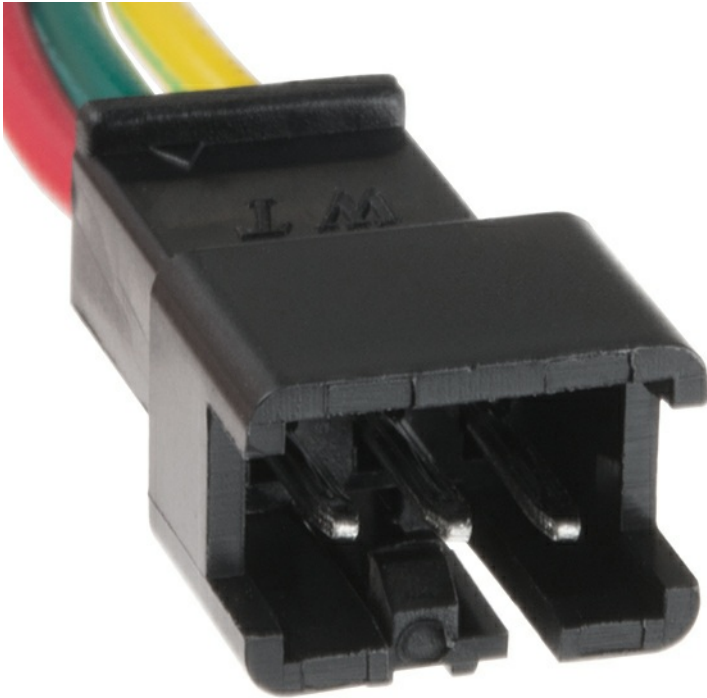

Female Housing, Typically the Input Side for WS2812's

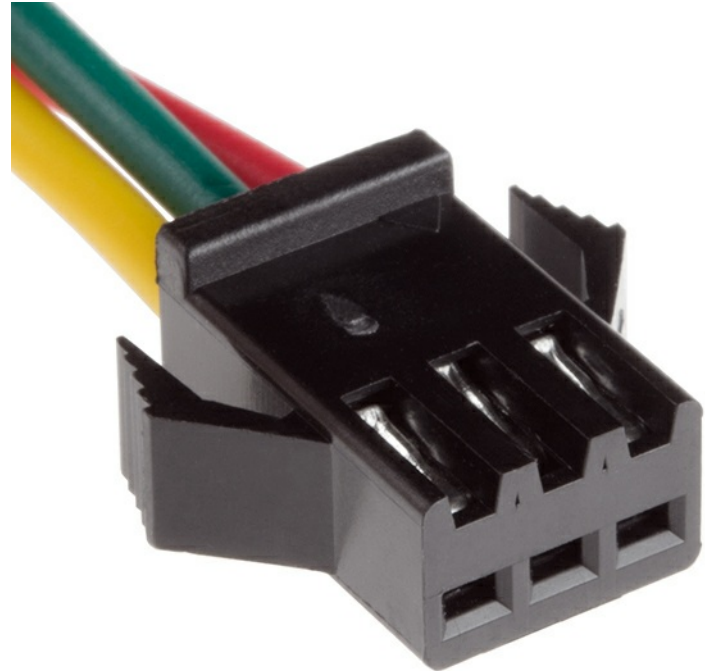

Male Housing, Typically the Output Side for WS2812's

Heads up! Depending on the manufacturer, the color wires can vary. Additionally, the female housing may be connected to the output side and vice versa. Just make sure to follow the wires to the LED strip's pad to ensure that they are properly connected.

For the first strip in a string, you can either connect to a mating connector, or cut and strip the wires, and connect them to your controlling device. To reuse the rest of the LED strip, check out the LED strip pigtail connector to easily connect the cut strips:



[LED Strip Pigtail Connector \(3-pin\)](#)

CAB-14575

\$1.50

[Favorited Favorite 7](#)

[Wish List](#)

Note: For prototyping on a breadboard, you could use M/M or F/M jumper wires to connect to the JST-SM connector. If you are using a LilyPad or micro:bit, you can also connect using the alligator clips with male or female header.



[Alligator Clip with Pigtail \(10 Pack\)](#)

CAB-14303

\$7.50

4

[Favorited Favorite](#) 13

[Wish List](#)



[Alligator Clip with Female Header \(10 Pack\)](#)

CAB-15186

\$7.50

[Favorited Favorite](#) 9

[Wish List](#)



[Jumper Wires Premium 6" M/M Pack of 10](#)

PRT-08431

\$4.50

2

[Favorited Favorite](#) 12

[Wish List](#)



[Jumper Wires Premium 6" M/F Pack of 10](#)

PRT-09140

\$4.50

1

[Favorited Favorite](#) 16

[Wish List](#)

Addressable Through-Hole LED

If you require WS2812 LEDs in through-hole form, they are also available as a through-hole package.



Diffused 8mm addressable LEDs connected on a breadboard.

The size of the bulb can either be 8mm or 5mm. The LEDs can be diffused or clear depending on how they were manufactured.

- [Diffused 8mm \(5 Pack\)](#)
- [Diffused 5mm \(5 Pack\)](#)
- [Clear 5mm \(5 Pack\)](#)

Through-Hole LED Pinout

The datasheet for the WS2812 addressable through-hole LEDs is not clear with the pinout. For reference, you can refer to the bulb's flat edge and the length of the terminals as indicated below.

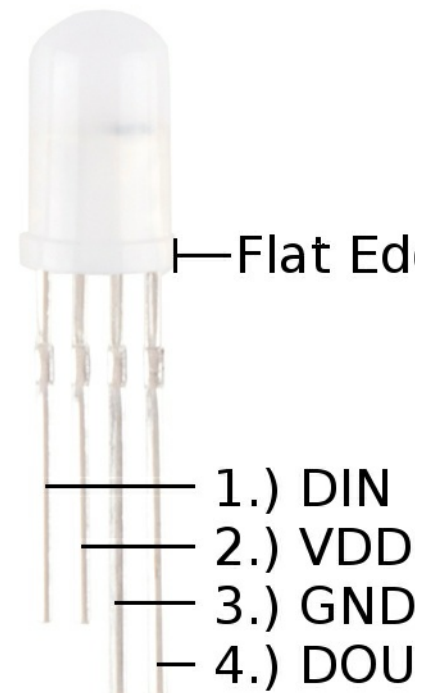
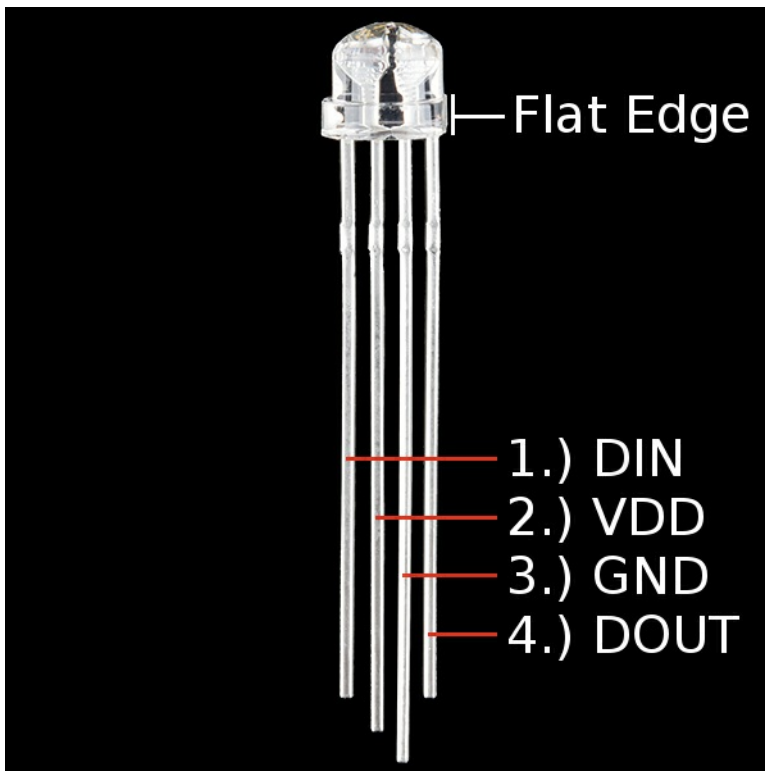

Note: Just like the WS2812 breakout boards, we recommend adding a $0.1 \mu\text{F}$ capacitor between each WS2812 LED's VDD and GND.

Hardware Hookup

The great thing about these LEDs is they're super easy to chain together. Plus just one, single pin from your microcontroller is required to control an entire strip of LEDs. In this example, we'll link together five LEDs, but you should be safe to increase that ten-fold or even more.

Solder/Sew/Wire Something

The first assembly step for each of these products is creating a reliable, electrical connection from the LED to your control board. You'll need to [solder](#) either headers or wires to your breakout boards. Or sew your LilyPad Pixel with [conductive thread](#). Or [strip and splice some wire](#) to connect up the LED strips.

[How to Solder: Through-Hole Soldering](#)

[September 19, 2013](#)

This tutorial covers everything you need to know about through-hole soldering.
[Favorited Favorite](#) 75

[LilyPad Basics: E-Sewing](#)

[December 17, 2016](#)

Learn how to use conductive thread with LilyPad components.
[Favorited Favorite](#) 17

[Working with Wire](#)

[February 8, 2013](#)

How to strip, crimp, and work with wire.
[Favorited Favorite](#) 52

If you're going to stick the boards into a breadboard or other prototyping board, [straight male headers](#) might be the best choice.

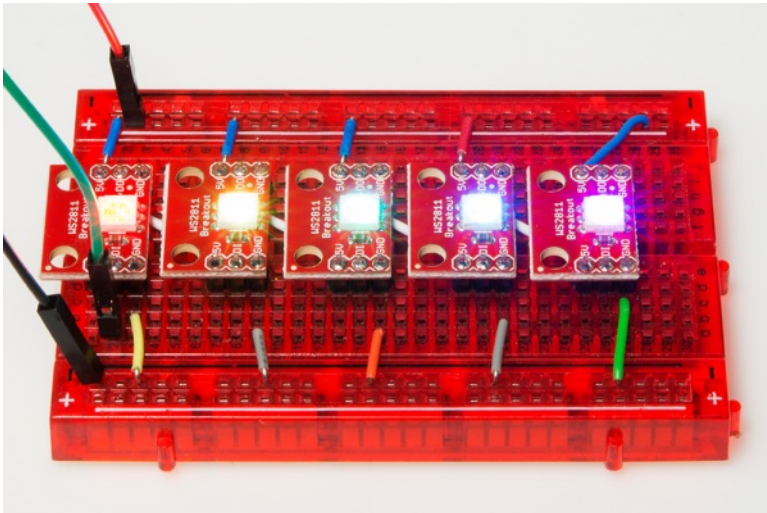

The older WS2812 breakouts linked together on a breadboard. Hidden under each is a white wire that connects DO of one to DI of the next.

If you're going to make a big strip of boards, you may need to opt for the [stranded wire](#) route.

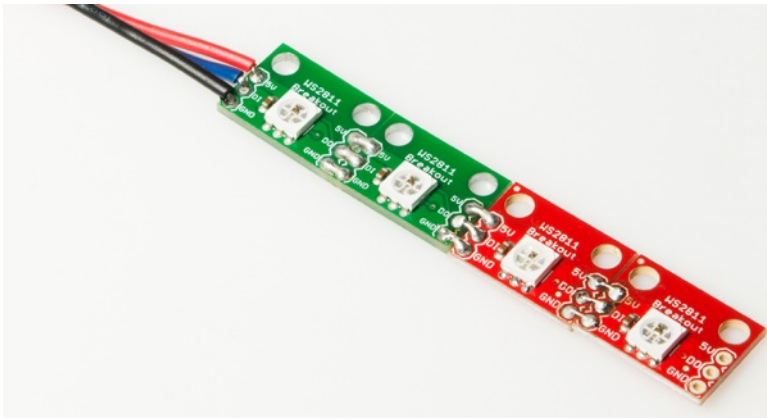

Link WS2812-based boards together in a chain, by connecting DIs to DOs (don't forget power too). Sorry, the fancy green boards aren't available :(.

Select a Power Source

The WS2812 and WS2812B requires about 5V to work. The WS2812 should operate at anywhere between about **4V to 7V** while the WS2812B should operate at anywhere between about **3.3V to 5V**. 5V is readily-available on most boards. The 5V header on an Arduino board, for example, is a perfect voltage supply for the LEDs.

Also consider how much current your LED strip is going to pull. With every single LED on at full brightness, each breakout board can pull about **60mA (20mA per color channel)**. Even with just ten breakout boards strung together, you're looking at upwards of a possible 600mA. Yikes! Below are a few power supplies that can power a few addressable LEDs. You may need an additional adapter or cable to connect.



[Wall Adapter Power Supply - 5VDC, 2A \(Barrel Jack\)](#)

TOL-15312
\$6.50
2
[Favorited](#) [Favorite](#) 15
[Wish List](#)



[Wall Adapter Power Supply - 5.1V DC 2.5A \(USB Micro-B\)](#)

TOL-13831
\$8.95
22
[Favorited](#) [Favorite](#) 48
[Wish List](#)



[USB Wall Charger - 5V, 1A \(Black\)](#)

TOL-11456
\$4.50
2
[Favorited](#) [Favorite](#) 13

[Wish List](#)

If you're stringing together a lot of these things, make sure your power supply can provide the necessary current-umph. If you end up using an external power supply, make sure you connect the power supply ground to your Arduino ground as well. Here are a few options in our catalog. Make sure to add an additional adapter to your cart as listed in the recommended products.



[Mean Well Switching Power Supply - 5VDC, 20A](#)

TOL-14098

Retired

[Favorited Favorite](#) 19

[Wish List](#)



[Mean Well LED Switching Power Supply - 5VDC, 5A](#)

TOL-14601

Retired

[Favorited Favorite](#) 8

[Wish List](#)



[Mean Well LED Switching Power Supply - 5VDC, 8A](#)

TOL-14602

1 Retired

[Favorited Favorite](#) 7

[Wish List](#)

Connecting an Arduino

This hookup is fairly straightforward. You can power the breakout board(s) using the Arduino's **5V** and **GND** pins. Then all you need is to pick a free I/O pin to send data to the LED. Let's go with **pin 4**. To link more breakouts together, simply connect the output pin of one to the input of the next. Make sure each breakout also gets some power delivered to it.

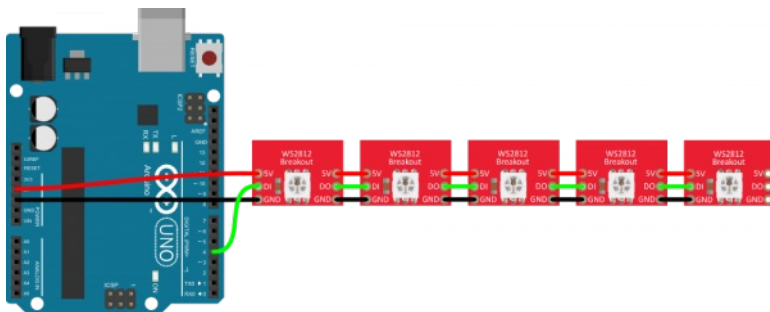

Protect Your WS2812's!

In addition to the hookup above, we recommend adding a capacitor and resistor as close as possible to your addressable LEDs to help you get the most out of your WS2812-based devices for long strips. Below is an example with an addressable LED strip. Read below for more information on suggested values!

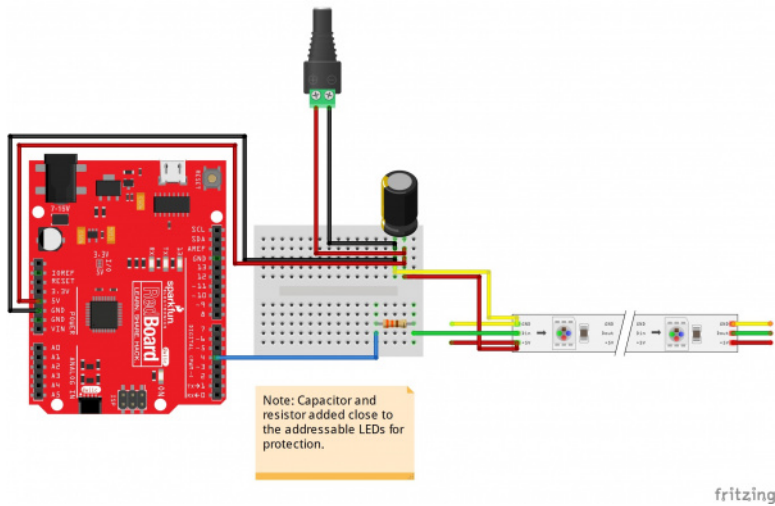

Add a Big Smoothing Capacitor

Before connecting the WS2812 to a power source, connect a big capacitor from power to ground. A cap between [100µF](#) and [1000µF](#) should be good.



This cap will help to smooth out your power supply. The current draw of a WS2812 can vary wildly, and as current draw grows and shrinks it'll be up to your power source to compensate. The cap will act as a "power reservoir" to store energy in case the supply dips.

Try to place this cap as **close to your WS2812 as possible** by placing it in parallel to the Vcc and GND pins.

Add an In-Line Resistor On the Data Signal

Placing a small-ish resistor between your Arduino's data output and the WS2812's data input will help protect the data pin. [A resistor between 220 and 470 Ω](#) should do nicely. Try to place the resistor as close to the WS2812 as possible.



A 330Ω resistor that could be used between the Arduino's I/O pin and the WS2812's data input pin.

Keep Wires Short!

Wires don't conduct perfectly. They'll inevitably induce some voltage loss, especially when they're really long. Try to keep wires between your power supply, Arduino, and WS2812 as short as possible to minimize this loss.

Power Large Loads and Daisy Chained LED Strips

For more information on daisy chaining LED strips, check out this section that talks about avoiding voltage drops.



Voltage Drops Along the Daisy Chained LED Strips in [Mean Well LED Switching Power Supply Hookup Guide: Power Large Loads and Daisy Chained LED Strips](#)

Adding Firmware

Note: This example assumes you are using the latest version of the Arduino IDE on your desktop. If this is your first time using Arduino, please review our tutorial on [installing the Arduino IDE](#). If you have not previously installed an Arduino library, please check out our [installation guide](#).

For our example code, we'll be making use of Adafruit's fantastic [NeoPixel library](#). Click below to download a copy of both the example code, as well as the NeoPixel library.

[Arduino Example and NeoPixel Library \(ZIP\)](#)

The library is located in the "Adafruit_NeoPixel" folder, and the example code is found in the "WS2812_Breakout_Example" folder.

With the library installed, open up **WS2812_Breakout_Example.ino** within Arduino. Before you upload the code, make sure you adjust the `PIN` and `LED_COUNT` definitions near the top of the sketch. These define which pin the first pixel is connected to, and how many total LEDs are linked up. Then upload away and enjoy the show!

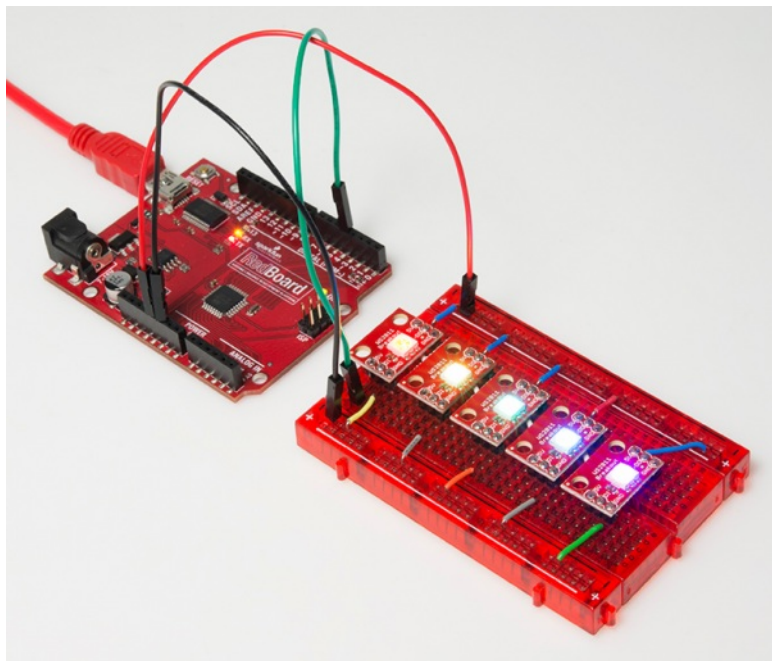

Using the NeoPixel Library

Setup

There are a few lines of code required to set up your sketch to use the library. First, **call the constructor** near the top of your code (before `setup()`, you'll probably want it to be a global variable).

```
language:c
```

```
#define PIN 4
#define LED_COUNT 8

// Create an instance of the Adafruit_NeoPixel class called "leds".
// That'll be what we refer to from here on...
Adafruit_NeoPixel leds = Adafruit_NeoPixel(LED_COUNT, PIN, NEO_GRB + NEO_KHZ800);
```

The PIN and LED_COUNT parameters in that function call should be set, respectively, to the **Arduino pin** you've connected to the first breakout's "DIN" pin and the total **number of breakout boards** you have linked up.

The rest of the setup is calling the `leds.begin()` function somewhere near the beginning of the `setup()` function.

Setting An LED

Setting an LED with the Adafruit NeoPixel library is a two step process. First, you have to set a pixel color using the `leds.setPixelColor(position, color)` command. The color parameter in that function can either be a 24-bit RGB color-code, or three separate bytes for each color. For example:

```
language:c
leds.setPixelColor(3, 0xFF00FF); // Set fourth LED to full red, no green, full blue
leds.setPixelColor(3, 0xFF, 0x00, 0xFF) // Also set fourth LED to full red, no green, full blue
```

Setting a pixel's color does not equate to that pixel actually turning on though. For that, you need to call `leds.show()`. Note that when this function is called *any* LED that was previously set will turn on.

The Rest of the Code

After you've gotten the hang of using the NeoPixel library, the remaining parts of the sketch are finding ways to manipulate the pixel colors. There are some fun functions in this example code, which create the classic "cylon" Larson scanner, or draw a rainbow. We hope you can adapt them to make even more creative animations.

The included "WS2812_Definitions.h" file defines a huge list of standard colors. In there you'll find anything from **navy** to **saddle brown** to **ghost white**.

Have fun!

FastLED Alternative Library

Looking for an alternative library? Try checking out the FastLED library for more advanced features. The library also [supports other LED chipsets](#).

[FastLED GitHub Repo](#)

Resources and Going Further

For more information about the WS2812 and WS2812B, check out the resources below:

- [Breakout Board Schematic \(PDF\)](#)
- [Breakout Board Eagle Files \(ZIP\)](#)
- [Breakout Board GitHub Repo](#)
- Datasheet
 - [WS2812 \(PDF\)](#)
 - [WS2812B \(PDF\)](#)
 - [Differences between WS2812 vs WS2812B \(PDF\)](#)
- [Example Code and NeoPixel Library \(ZIP\)](#)
- [Adafruit NeoPixel Library GitHub Repo](#)
- [FastLED Library GitHub Repo](#)

Now that you've got the gist of the WS2812 Breakout board, how are you going to use it in a project? Need some inspiration? Check out these tutorials:

- [Using OpenSegment](#) -- The OpenSegment is a very large, 4-digit 7-segment display. If you're on a blinky-high after playing with the WS2812 LEDs, this is another fun component to play with.
- [Getting Started with the LilyPad MP3 Player](#) -- If you're into e-textiles (or even if you're not, this thing is awesome), check out the LilyPad MP3 Player. Combine the LilyPad MP3 player with the WS2812 to make a nifty LED-music show.
- [Designing PCBs: Advanced SMD](#) -- If you'd like to lay out your own, custom PCB for the WS2812 LED/chip, check out this tutorial. It'll walk you through every step required to design your very own circuit board using free software. You can use the WS2812 footprint from our [parts library](#) to get started.

Building Large LED Installations

Learn what it takes to build large LED installations from planning to power requirements to execution.

[Favorited Favorite 21](#)

Interactive LED Music Visualizer

Use an Arduino and the SparkFun Sound Detector to create visualizations on Addressable RGB LED strips.

[Favorited Favorite 28](#)

LED Cloud-Connected Cloud

Make an RGB colored cloud light! You can also control it from your phone, or hook up to the weather!

[Favorited Favorite](#) 31

[Addressable LED Strip Hookup Guide](#)

Add blinking lights to any holiday decoration with our Holiday Lights Kit using WS2812-based addressable LEDs!

[Favorited Favorite](#) 11

[Mean Well LED Switching Power Supply Hookup Guide](#)

In this tutorial, we will be connecting a Mean Well LED switching power supply to an addressable LED strip controlled by an Arduino.

[Favorited Favorite](#) 3

Check out these projects using the WS2812 addressable LEDs for more ideas:

[Enginursday: Sound Wave Printing](#)

[January 5, 2017](#)

[Favorited Favorite](#) 1

[Backlit LED Mountain Scene](#)

[April 25, 2017](#)

[Favorited Favorite](#) 7

[Hardware Hump Day: Blade Runner Parasol](#)

[October 4, 2017](#)

[Favorited Favorite](#) 1

[Enginursday: X-Band Motion-Triggered Music](#)

[June 29, 2017](#)

[Favorited Favorite](#) 2

[Fashion Hacking: Infinity Mirror Heart Heels](#)

[February 13, 2018](#)

[Favorited Favorite](#) 1

[Nixie LED Clock](#)

[May 8, 2018](#)

[Favorited Favorite](#) 5

[ATP: Circuit Design with LEDs](#)

[July 2, 2018](#)

[Favorited Favorite](#) 0

[DIY Desktop Light Sculpture](#)

[July 31, 2018](#)

[Favorited Favorite](#) 6

[Enginursday: LED Guitar for Decadon](#)

[August 16, 2018](#)

[Favorited Favorite](#) 1

[Wearable Tech at Dragon Con, Part 1](#)

[September 13, 2018](#)

[Favorited Favorite](#) 1

[Wearable Tech at Dragon Con: Part 2](#)

[September 20, 2018](#)

[Favorited Favorite](#) 0

[Enginursday: Glowing Guitar, Part Deux](#)

[November 15, 2018](#)

[Favorited Favorite](#) 7

[DIY Edge-Lit Acrylic Display](#)

[March 12, 2019](#)

[Favorited Favorite](#) 8

[Expecto Patronum!](#)

[February 12, 2019](#)

[Favorited Favorite](#) 4

Or check out this project using the APA102's for some more edge lighting ideas:

[Enginursday: Ten Years of Testbeds](#)

[October 10, 2019](#)

[Favorited Favorite](#) 1

learn.sparkfun.com | [CC BY-SA 3.0](https://creativecommons.org/licenses/by-sa/3.0/) | SparkFun Electronics | Niwot, Colorado